

# CENTAFLEX®-A

highly flexible couplings

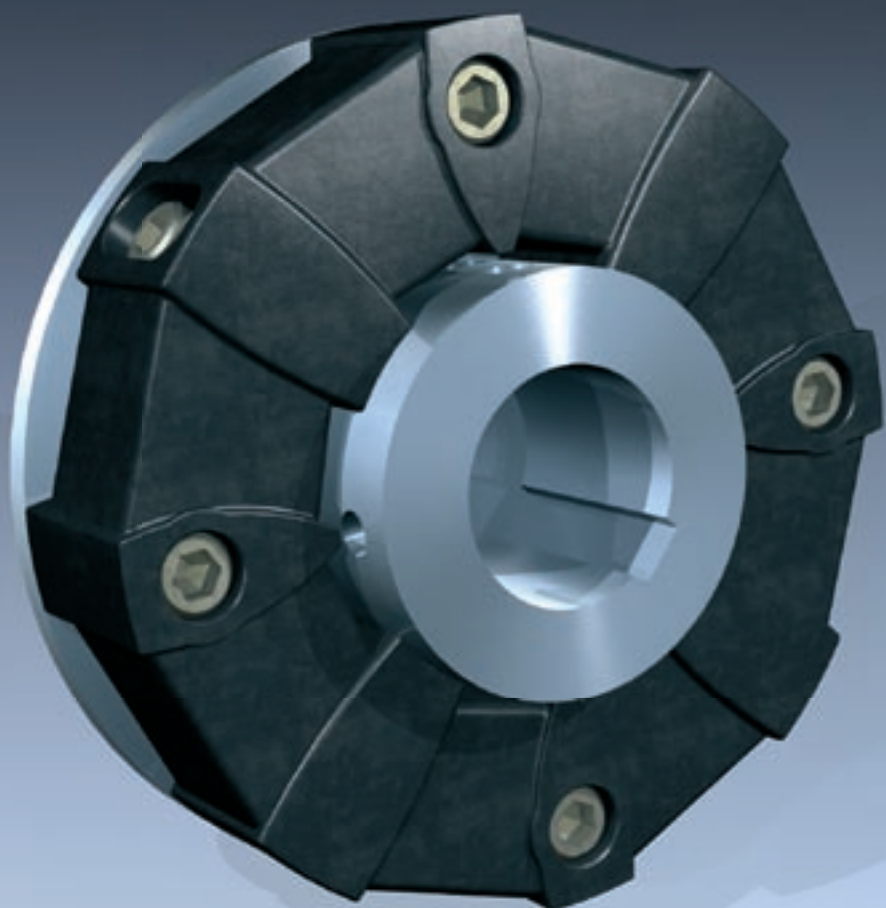

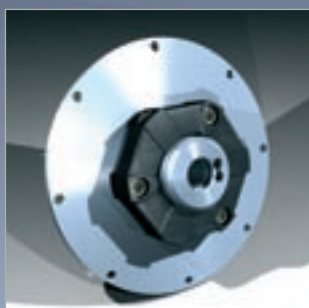

# CENTAFLEX®

# The success of a coupling system

The CENTAFLEX -coupling was developed by CENTA Antriebe in West Germany and introduced to the market in 1970. It is patented in all industrial countries. It is also being manufactured under license in two other countries:

The Miki Pulley Co. Ltd.- Japan  
and Lovejoy Inc. - USA

In 1979 CENTA Transmissions Ltd., an associate company of CENTA Antriebe was formed in England. Meanwhile the manufacture of the CENTAFLEX-couplings increased to over 250.000 units per year. Now more than 25 agencies guarantee worldwide service and availability of CENTAFLEX-couplings.

## The idea

A high quality coupling element which - with very little effort - enables a highly flexible coupling to be "custom built" for almost any purpose. The CENTAFLEX contains a highly elastic element which is extensively flexible in any direction, and upon which an entire coupling system is based. This coupling system embodies a combination of numerous positive characteristics, with a versatility of design from common components, not previously achieved.

## The principle

A pre-stressed polygon shaped rubber element with metal parts vulcanised in. The important innovation is that the screws connecting the rubber element with the hubs are alternately arranged axially and radially. The radial screws fulfill 2 tasks:

- \* connecting the rubber element to the hub
- \* producing a pre-load by radial compression of the rubber column

Pre-load pressure stress in the

rubber element considerably raises the capacity of the coupling, since it compensates for the tensile stress which otherwise occurs in operation. Under compressive stress the capacity of rubber is multiplied.

Transmission of the peripheral force from the bonded aluminium segments to the hubs is by friction. The stress in the screws is therefore purely tensile and in no way a flexional or shearing stress. For better frictional engagement, the cylindrical hubs for most sizes are knurled on the perimeter. During assembly, the knurl points press into the aluminium and result in a highly stressable combination giving a positive and friction locking connection.

## The materials

Precision die-cast aluminium parts, vulcanised into high quality rubber; high tensile self-securing screws and steel hubs machined all over.

## The hubs

The hubs have very simple cylindrical or flat mating faces without cams or recesses.

This means that other existing elements (e.g. flywheels, brake discs, clutches, pulleys, gears etc.) can easily be used as hubs. All that is necessary in such cases is to drill and tap a few holes for fastening the rubber element. The simple, easily manufactured form of the hubs permits the manufacture of many special designs, such as elongated hubs.

The CENTAFLEX system

An entire system with the most varied designs and hubs was developed, based on the advantages described above. In addition there are hundreds of special designs. This catalog describes only the important highly flexible designs of the CENTAFLEX system. Apart from these, several varieties with higher torsional stiffness of the elastic element have been developed, which provide - with the same connecting dimensions and hubs - for further interesting designs in other areas of applications:

CENTAFLEX type H - torsionally stiff, for diesel hydraulic drives

CENTAFLEX type X - torsionally very stiff, angularly flexible free of play and backlash.

**CENTA DRIVES**  
of high technical standards.

\* CENTAFLEX is a registered trademark of CENTA Antriebe

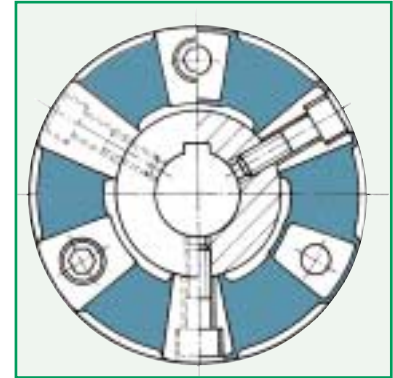
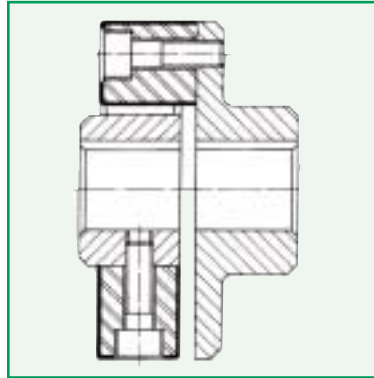

### Characteristics and advantages of the CENTAFLEX-couplings

- = Simple, compact, smooth-face design
- = Low weight, low moment of inertia
- = High performance, high speed range, large bores permitted, ruptureproof
- = Large angle of twist with progressive characteristic curve (approx. 6-8° at nominal torque)
- = High elasticity and considerable flexibility in any direction (radial, axial, angular) with low counter forces on shafts and bearings. Therefore the shafts do not have to be aligned accurately
- = The action of the CENTAFLEX coupling is shock and vibration absorbing
- = The torque is transmitted absolutely free from play, uniformly, free from noise, and electrically insulating
- = The coupling requires no maintenance, the rubber parts suffer no wear, providing long useful life with no dirt produced by rubber particles
- = The rubber element is air flushed all around; the heat generated is easily conducted away and the rubber element remains cool
- = The rubber element can easily be fitted and dismantled without the use of special tools or tension bands
- = The coupling can be very easily aligned, relying on line of sight or with the aid of a straight edge, without any special templates or gauges
- = The elements can be dismantled transversely without any axial displacement
- = By slackening the radial screws, the drive can easily be separated and rotated without dismantling
- = No axial reaction forces are imposed on shafts and bearings due to the transmission of torque
- = Rubber elements are available in various shorehardness grades. This permits variation of the torsional stiffness within wide limits and its adaption to the vibrational requirements of each drive system
- = The rubber elements are available in various materials:  
Standard: natural rubber  
Special materials: Perbunan, Neoprene etc.

## CENTAFLEX- the coupling with the 5-way-flex

Every good elastic coupling has 4-way flexibility:

1. torsional elasticity
2. radial flexibility
3. axial flexibility
4. angular flexibility

In addition, the CENTAFLEX is uniquely flexible in application, i.e. capable of modification and adaption; CENTAFLEX therefore has 5-way flexibility.

## CENTAFLEX coupling design types

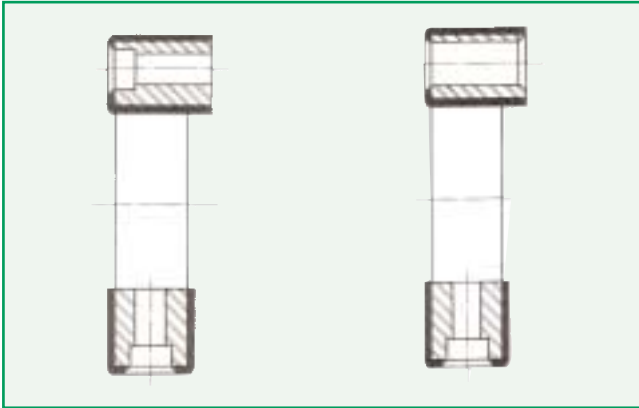

### Type 0 and 0-S

The rubber element for customers' "own designed" special applications. Available in various shorehardness grades and materials.

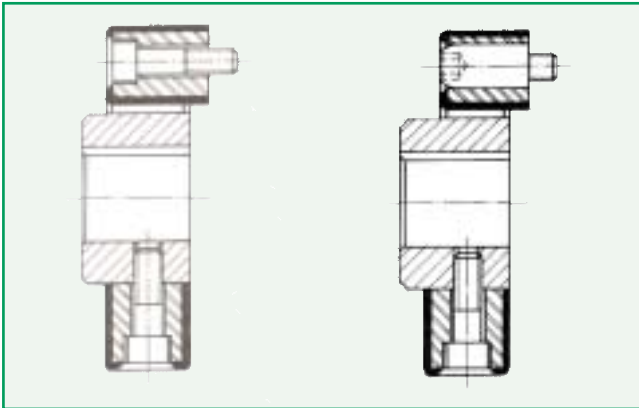

### Type 1 and 1-S

Element with cylindrical hub for existing drive elements, e.g. flywheels, pulleys, brake discs, friction clutches, universal joints, freewheels, gears.

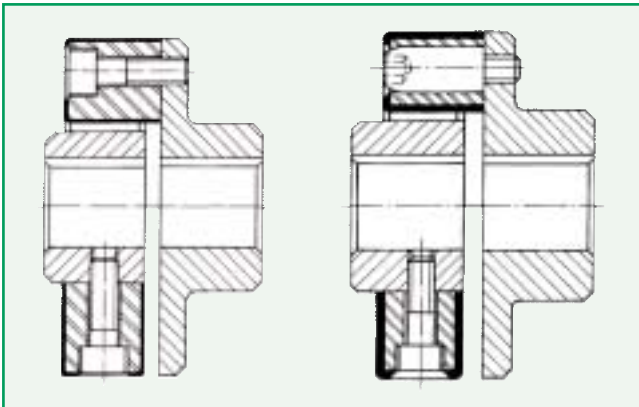

### Type 2 and 2-S

Complete shaft couplings for all areas of mechanical engineering. After removing the axial screws, coupled machines can be removed radially, as with "three-part" couplings.

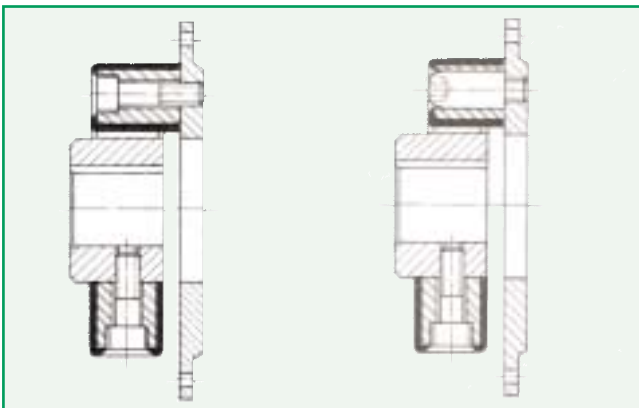

### Type 3 and 3-S

Flanged couplings for combustion engines and many other applications. The simple adaptor plate can be adapted to fit any standard or non-standard flywheel or other component.

**Type S**

Design "S" is a plug-in variation for applications where axial movement or "blind" assembly in a housing is required. Design "S" is available for all design types and sizes of CENTAFLEX. In addition, there are

special designs available with extended socket bolts for applications requiring large axial movement or the provision of facilities to change V-belts.

**Universal joint shaft, type G**

Highly elastic universal joint shafts for any assembly length and for a variety of applications. Connecting pieces can be varied as required, and are adaptable. With short assembly length they are suitable for speeds up to 3000 rpm.

Never surpassed for simplicity and economic pricing!

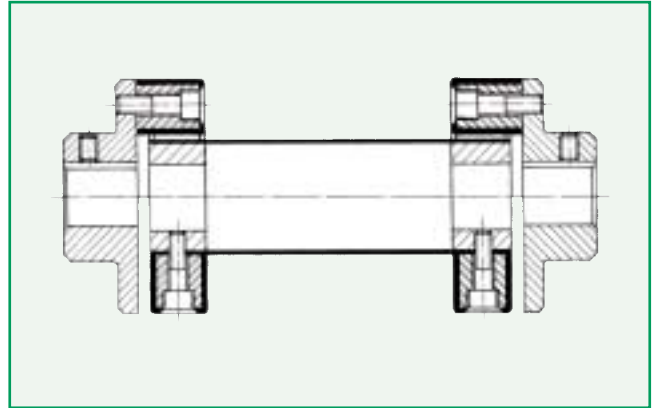

**Universal joint shaft, type GZ**

Highly elastic universal joint shafts with accurate, maintenance-free centering of the central part for applications with very high speeds and/or long shaft lengths.

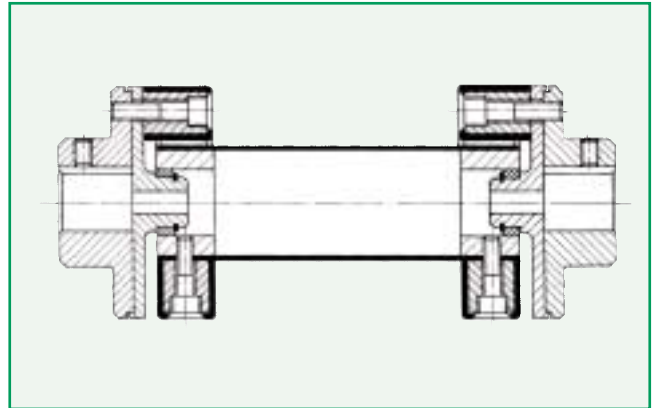

**CENTAFLEX design H**

Torsionally stiff, plug-in, high temperature and oil-resistant design series, specially designed for diesel hydraulic drives. Numerous design types identical to those previously described, and with further special designs.

Detailed description is given in catalog CF-H.

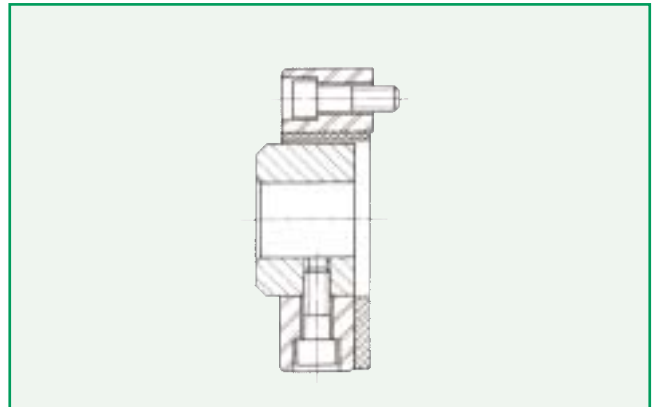

**CENTAFLEX design X**

Torsionally very stiff design series, free from play or backlash, but axially and angularly flexible. This series is temperature and oil resistant. Plug-in types suitable for blind fitting, or axially stiff types are available. This series is especially suitable for torsionally stiff universal joint shafts identical to the above design type G.

Detailed description is given in catalog CF-X.

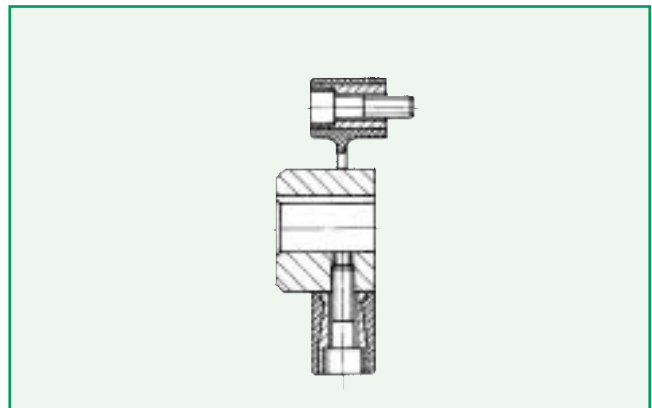



## A 1.0 Performance table

CENTAFLEX size			1	2	4	8	12	16	22	25	28	30	50	80	90	140	200	250	400	remarks	
1	Nominal torque	$T_{KN}$	Nm	10	20	50	100	140	200	275	315	420	500	700	900	1100	1700	2400	3000	5000	
2	Maximum torque	$T_{Kmax}$	Nm	25	60	125	280	360	560	750	875	1200	1400	2100	2100	3150	4900	6000	8750	12500	
3	Angle of twist	$T_{KN}$	grad	6°	6°	5°	5°	3°	5°	3°	5°	3°	5°	3°	3°	5°	3°	3°	3°	3°	3°
		$T_{Kmax}$	grad	17°	17°	12°	14°	7,5°	14°	7,5°	14°	7,5°	14°	7,5°	7,5°	14°	7,5°	7,5°	7,5°	7,5°	7,5°
4	max. speed	$n_{max}$	min <sup>-1</sup>	10000	8000	7000	6500	6500	6000	6000	5000	5000	4000	4000	4000	3600	3600	3000	3000	2500	
5	angular elasticity	$DK_W$	grad	3°	3°	3°	3°	2°	3°	2°	3°	2°	3°	2°	2°	3°	2°	2°	2°	2°	dependant upon speed
6	axial elasticity	$DK_a$	mm	2	3	3	4	4	5	5	5	5	5	5	3	5	5	5	5	5	
7	radial elasticity	$DK_r$	mm	1,5	1,5	1,5	2	2	2	2	2	2	2	2	2	1,5	2	2	2	2	dependant upon speed
8	cont. oscillating torque	$T_{KW}$	Nm	5	10	20	40	50	80	100	125	150	200	300	320	450	700	960	1250	2000	
9	allowable energy loss	$P_{KV}$	W	6	10	15	25	30	40	50	68	75	80	90	100	120	150	170	200	250	
10	dyn. torsional stiffness	$C_{Tdyn}$	Nm/rad	90	180	550	900	2700	2000	6100	2800	7500	4800	12000	16000	10500	26500	38700	43000	75000	50 Shore
		$C_{Tdyn}$	Nm/rad	140	290	850	1500	4400	3400	9000	4500	12000	7800	19000	25000	16000	40000	60000	67000	120000	60 Shore
11	Axial-stiffness	$C_a$	N/mm	38	22	75	75	250	100	500	140	550	190	650	850	220	650	900	1150	1300	
12	Radial-stiffness	$C_r$	N/mm	150	150	500	500	1000	500	1300	600	1400	750	2200	2900	1000	2300	3100	4100	6000	
13	angular stiffness	$C_w$	Nm/grad	0,3	0,3	2,4	3,6	9,0	5,0	12,0	7,0	17,0	9,0	26,0	34,0	17,0	38,0	48,0	68,0	88,0	

Figures given for Pos. 3, 11, 12, 13 are values for a shorehardness of 60° measured statically ( $C_{dyn} = C_{stat} \cdot 1,3$ )

Nominal torque  $T_{KN}$ :

Torque which can be transmitted throughout the entire permitted speed range.

Maximum torque  $T_{Kmax}$ :

Torque which may be applied for short periods  $10^5$  times, pulsating in the same direction of rotation, or  $5 \times 10^4$  alternating

Continuously oscillating torque  $T_{KW}$ :

Amplitude of continuously permissible torque fluctuation at max. frequency of 10Hz and a basic load up to nominal torque  $T_{KN}$

### A 1.1 Starting up factor

Z	£120	120 < Z £ 240	>240
$S_z$	1,0	1,3	ask CENTA

Z = start frequency per hour

### A 1.2 Frequency factor

f in Hz	£ 10	> 10
$S_f$	1	$\sqrt{\frac{f}{10}}$

### A 1.3 Shorehardness

Conversion factor u				
Shore	50	60	70	75
u	0,7	1	1,6	2,3

### A 1.4 Surge or Pulse factor

SA/SL	
1,6	Light starting load
1,9	Medium starting load
2,2	Heavy starting load

### A 1.5 Resonance factor $V_R$ relative damping $\psi$

Natural rubber(NR)		
Shore	VR	$\psi$
50	10	0,6
60	8	0,78

### A 1.6 Temperature factor

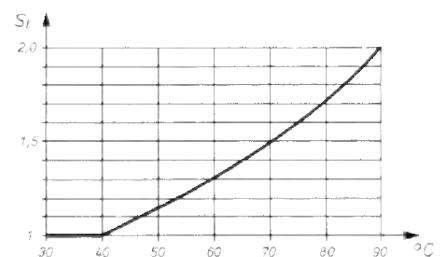

### A 1.7 Permissible angular and radial misalignment

permissible angular and parallel offset misalignment is dependant upon the speed when utilising the nominal torque capacity. % of line 5 or 7

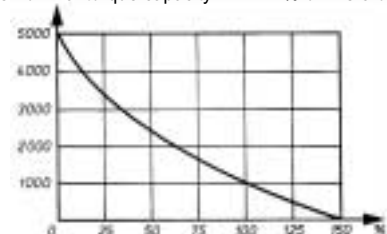

## Coupling selection

The CENTAFLEX-coupling must be suitable dimensioned to prevent the stresses:

- Nominal torque  $T_{KN}$
- Maximum torque  $T_{Kmax}$
- Continuously oscillating torque  $T_{KW}$

from exceeding the permissible values in any operational state. The following formulae will be helpful.

### Stress due to the torque

The permissible nominal torque at all operating temperatures must be at least as great as the nominal torque of the drive or load side.

$$T_{AN} \cdot S_t \geq T_{KN} \neq T_{LN} \cdot S_t$$

Factors of influence:

Nominal torque	drive side	$T_{AN}$	Nm
	load side	$T_{LN}$	Nm
Temperature factor	$S_t$	(diagram A 1.6)	

Performance formula:

$$T_{AN} \left| T_{KN} \right| T_{LN} = 9555 \frac{P \cdot kW}{n \cdot rpm} \quad Nm$$

### Stress due to torque pulses:

The permissible max. torque of the coupling must at all operating temperatures be at least as great as the torque pulses  $T_{AS}$  and  $T_{LS}$  (Nm) occurring in operation.

Factors of influence :

start-up factor  $S_Z$  (Table A 1.1)

pulse factor  
drive side  $S_A$  (Table A 1.4)

load side  $S_L$

Mass factor  
drive side  $M_A$

$$M_A = \frac{J_L}{I_A + I_L}$$

$$M_L = \frac{J_A}{J_A + J_L}$$

Drive side pulse

$$T_{Kmax} \neq M_A \cdot T_{AS} \cdot S_A \cdot S_Z \cdot S_t \quad Nm$$

Load side pulse

$$T_{Kmax} \neq M_L \cdot T_{LS} \cdot S_L \cdot S_Z \cdot S_t \quad Nm$$

### Stress due to a periodic oscillating torque Position of resonance (resonance speed)

For easier calculation, the existing unit is best reduced to a 2-mass torsional oscillating system if possible.

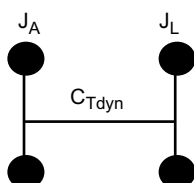

Total mass moment of inertia

drive side  $J_A$   $kgm^2$

load side  $J_L$   $kgm^2$

Dyn. torsional stiffness of the coupling  $C_{Tdyn}$   $Nm/rad$

### Determining the resonance speed of the i<sup>th</sup> order

$$n_R = \frac{30}{\pi \cdot i} \sqrt{C_{Tdyn} \frac{J_A + J_L}{J_A \cdot J_L}} \quad min^{-1}$$

$i$  = number of oscillations generated per revolution

### Distance from resonance

Where there is considerable oscillation generated, the resonance can be placed outside the operating speed range by the appropriate selection of the coupling torsional stiffness. The following applies for the required resonance distance:

$$\frac{n_B}{n_R} = 1,5 - 2$$

### Passing through resonance

The permissible max. torque  $T_{Kmax}$  must not be exceeded while running through the resonance.

Factors of influence:

generating torque

drive side  $T_{Ai}$   $Nm$

load side  $T_{Li}$   $Nm$

Resonance factor  $V_R$  (Table A 1.5)

Drive side oscillation generation

$$T_{Kmax} \neq M_A \cdot T_{Ai} \cdot V_R \cdot S_Z \cdot S_t \quad Nm$$

Load side oscillation generation

$$T_{Kmax} \neq M_L \cdot T_{Li} \cdot V_R \cdot S_Z \cdot S_t \quad Nm$$

### Continuously oscillating torque

For the operating frequency, the oscillating torque must be compared with the permissible continuously oscillating torque of the coupling. The continuously oscillating torque existing is dependant upon the amplifying factor outside the resonance.

Amplifying factor  $V$  outside the resonance.

$$\text{approximation formula} \quad V \sim \frac{1}{1(n/n_R)^2}$$

Drive side oscillation generation

$$T_{KW} \neq M_A \cdot T_{Ai} \cdot V \cdot S_t \cdot S_f \quad Nm$$

Load side oscillation generation

$$T_{KW} \neq M_L \cdot T_{Li} \cdot V \cdot S_t \cdot S_f \quad Nm$$

Frequency factor  $S_f$  (Table A 1.2)

We shall be pleased to carry out torsional vibration calculations for you in our offices.

All data, dimensions and information of this catalog are given without guarantee. Amendments and improvements may be made without notice. This technical document has legal protection (copyright).



# Dimensions, Basic Design Types 0, 1, 2, 0-S, 1-S, 2-S.

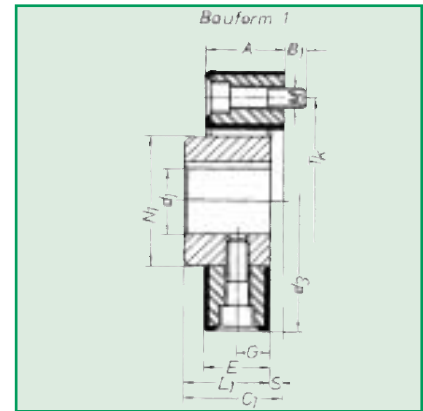
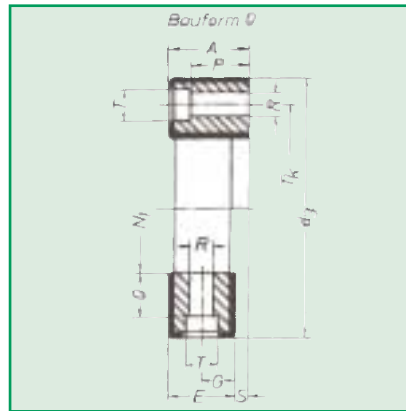

Size	d <sub>1</sub>		d <sub>2</sub>		d <sub>3</sub>	A	B	B <sub>1</sub>	C <sub>1</sub>	E	G	L <sub>1</sub>	L <sub>2</sub>	L <sub>3</sub>	M	N <sub>1</sub>	N <sub>2</sub>	S	T <sub>5</sub>
	min.	max.	min.	max.															
1	8	19		25	56	24	7	7	26	22	11	24	24	50	M 6	30	36	2	10
2	10	26		38	85	24	8	8	32	20	10	287	28	60	M 8	40	55	4	14
4	12	30		45	100	28	8	8	34	24	12	30	30	64	M 8	45	65	4	14
8		38		55	120	32	10	10	46	28	14	42	42	88	M 10	60	80	4	17
12		38		55	122	32	10	10	46	28	14	42	42	88	M 10	60	80	4	17
16		48		70	150	42	12	12	56	36	18	50	50	106	M 12	70	100	6	19
22		48		70	150	42	12	12	56	36	18	50	50	106	M 12	70	100	6	19
25		55		85	170	46	14	14	61	40	20	55	55	116	M 14	85	115	6	22
28		55		85	170	46	14	14	61	40	20	55	55	116	M 14	85	115	6	22
30		65		100	200	58	16	16	74	50	25	66	66	140	M 16	100	140	8	25
50		65		100	200	58	16	16	74	50	25	66	66	140	M 16	100	140	8	25
80		65		100	205	65	16	16	75	61	35	66	66	145	M 16	100	140	4	25
90		85		110	260	70	19	20	88	62	31	80	80	168	M 20	125	160	8	32
140		85		110	260	70	19	20	88	62	31	80	80	168	M 20	125	160	8	32
200		105		110	300	80	19	20	102	72	36	94	90	192	M 20	145	160	8	32
250		115		130	340	85	19	20	108	77	22,5 54,5	100	100	208	M 20	160	195	8	32
400		120		140	370	105	25	28	135	95	28,5 66,5	125	125	260	M 24	170	200	10	45

The CENTAFLEX couplings have been proven in many areas of mechanical engineering. The major area of application lies with diesel driven stationary and mobile

equipment as well as a very wide range of industrial applications. The photographs below illustrate some typical examples of application:

Boat drives, mechanical conveying and handling, agricultural machinery, front power take-off on diesel engines for the most varied applications.

## Typical examples of application for CENTAFLEX -couplings

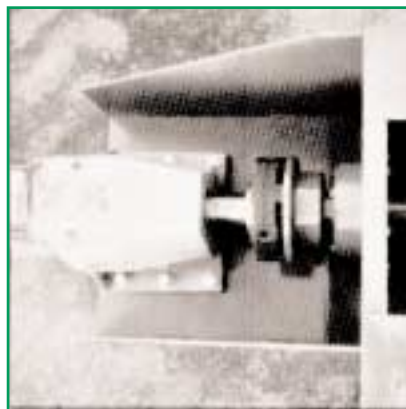

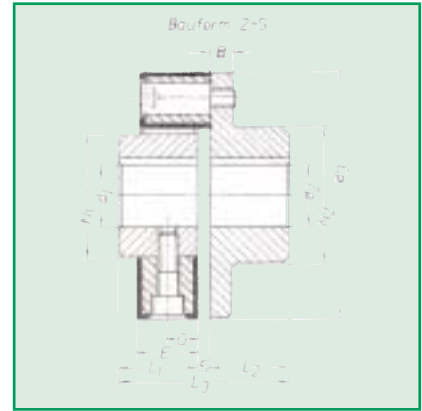
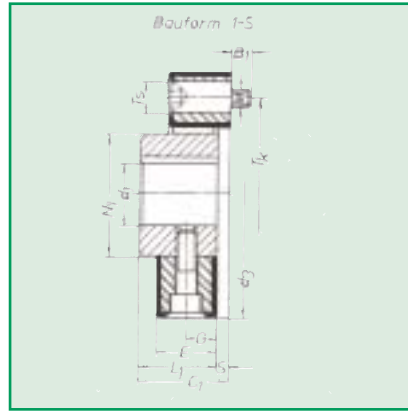
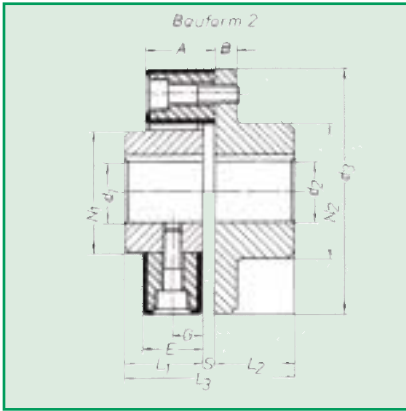

T	R	P	O	T <sub>K</sub> /Division	Weight kg					Mass moment of inertia J kgcm <sup>2</sup>					Size
					Type. 0	Type. 1	Type. 2	Type. 1/S	Type. 2/S	Type. 0	Type. 1	Type. 2	Type. 1/S	Type. 2/S	
10,5	6,5	18	5	44 / 2x180°	0,06	0,21	0,47	0,24	0,49	0,35	0,75	1,6	0,86	1,7	1
13,5	8,5	12	14,2	68 / 2x180°	0,15	0,46	1,06	0,49	1,09	1,25	2,5	7,3	3,3	8,1	2
13,5	8,5	17	18,5	80 / 3x120°	0,21	1,31	2,31	0,70	1,70	3,3	5,0	11,3	6,5	12,8	4
16,5	10,5	20,5	20,5	100 / 3x120°	0,32	1,35	3,45	1,44	3,54	7,0	15,0	41,0	18,6	44,6	8
16,5	10,5	20,5	20,5	100 / 4x 90°	0,35	1,45	3,55	1,56	3,66	8,4	18,2	44,2	20,0	46,1	12
18,5	12,5	23,5	25,2	125 / 3x120°	0,65	2,28	6,16	2,33	6,21	23,4	42,5	118,8	49,1	125,4	16
18,5	12,5	23,5	25,2	125 / 4x 90°	0,70	2,52	6,42	2,62	6,62	26,6	50,4	126,5	70,2	146,3	22
21,5	14,5	26,0	27,0	140 / 3x120°	0,84	3,59	9,31	3,77	9,49	50,2	90,7	215,0	102,7	227,0	25
21,5	14,5	26,0	27,0	140 / 4x 90°	0,95	3,79	9,51	4,05	9,76	55,6	102,4	247,8	113,2	258,5	28
24,5	16,5	34,5	34,5	165 / 3x120°	1,43	5,66	15,21	6,02	15,57	102,0	200,0	545,5	220,4	565,9	30
24,5	16,5	34,5	34,5	165 / 4x 90°	1,60	6,04	15,60	6,50	16,05	104,0	205,0	550,5	253,4	598,9	50
24,5	16,5	34,5	34,5	165 / 4x 90°	2,10	6,85	16,60	7,25	17,00	131,8	240,3	585,5	263,9	609,1	80
30,5	20,5	45,5	47,0	215 / 3x120°	3,30	11,55	28,67	12,23	29,35	450,0	657,5	1630,1	759,2	1731,8	90
30,5	20,5	45,5	47,0	215 / 4x 90°	3,65	12,33	29,45	13,22	30,36	572,0	770,0	1742,6	873,0	1845,6	140
30,5	20,5	44,5	45,5	250 / 4x 90°	5,75	13,13	33,16	14,07	34,11	1356,0	1598,0	3050,0	1686,0	3129,0	200
30,5	20,5	60,0	59,0	280 / 4x 90°	7,10	18,98	44,42	20,01	45,44	1754,0	2404,0	5264,0	2529,0	5389,0	250
42,5	24,5	72,0	77,0	300 / 4x 90°	11,25	26,58	57,23	29,34	59,95	3380,0	4485,0	9130,0	4683,0	9328,0	400

Elastic couplings mounted on friction clutches. The last photograph shows a particularly interesting application: A CENTAFLEX between an electric motor and

reduction gear, and a second CENTAFLEX coupling as a torsional oscillation damping and shock absorbing type of coupling in front of a chain drive.

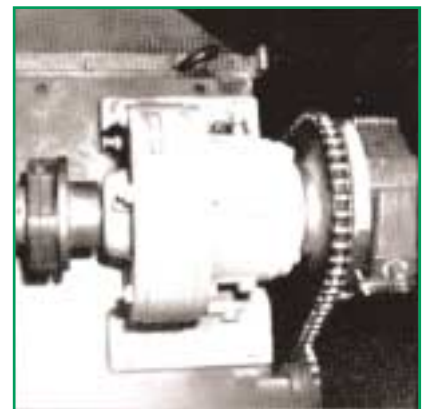
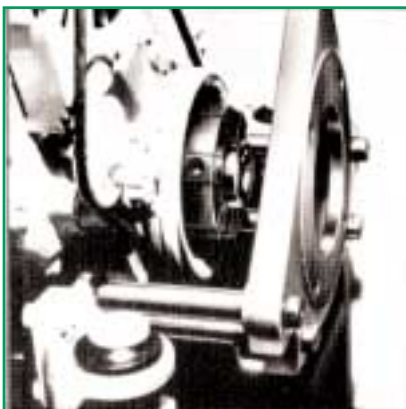



# CENTAFLEX- Universal Joint Shafts

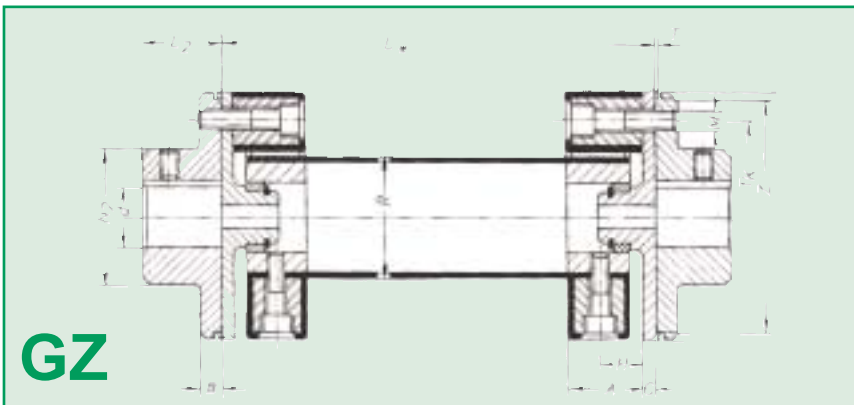
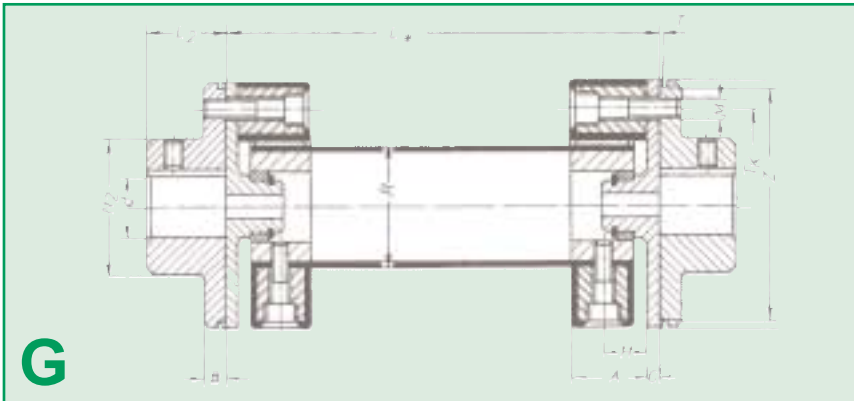

Size	T <sub>KN</sub> Nm	A	B	C	D	d		H	L <sub>2</sub>	N <sub>2</sub>	R	T	T <sub>K</sub>	M	Z <sup>H8</sup>
						min.	max.								
1	10	24	7	5	56	8	25	13	24	36	30	1,5	44	2x M 6	52
2	20	24	8	5	85	12	38	14	28	55	40	1,5	68	2x M 8	80
4	50	28	8	5	100	15	45	16	30	65	45	1,5	80	3x M 8	95
8	100	32	10	5	120	18	55	18	42	80	60	1,5	100	3x M10	115
12	140	32	10	5	122	18	55	18	42	80	60	1,5	100	4x M10	115
16	200	42	12	5	150	20	70	24	50	100	70	1,5	125	3x M12	145
22	275	42	12	5	150	20	70	24	50	100	70	1,5	125	4x M12	145
25	315	46	14	5	170	20	85	26	55	115	85	1,5	140	3x M14	165
28	420	46	14	5	170	20	85	26	55	115	85	1,5	140	4x M14	165
30	500	58	16	5	200	25	100	33	66	140	100	1,5	165	3x M16	195
50	700	58	16	5	200	25	100	33	66	140	100	1,5	165	4x M16	195
80	900	65	16	5	205	25	100	34,5	66	140	100	1,5	165	4x M16	195
90	1100	70	19	5	260	30	110	39	80	160	125	1,5	215	3x M20	250
140	1700	70	19	5	260	30	110	39	80	160	125	1,5	215	4x M20	250
200	2400	80	19	10	300	35	110	44	90	160	145	1,5	250	4x M20	290
250	3000	85	19	10	340	40	130	46	100	195	160	1,5	280	4x M20	330
400	5000	105	25	10	370	40	140	57	125	200	170	1,5	300	4x M24	360

Dimension "L" should be specified on enquiries and orders.

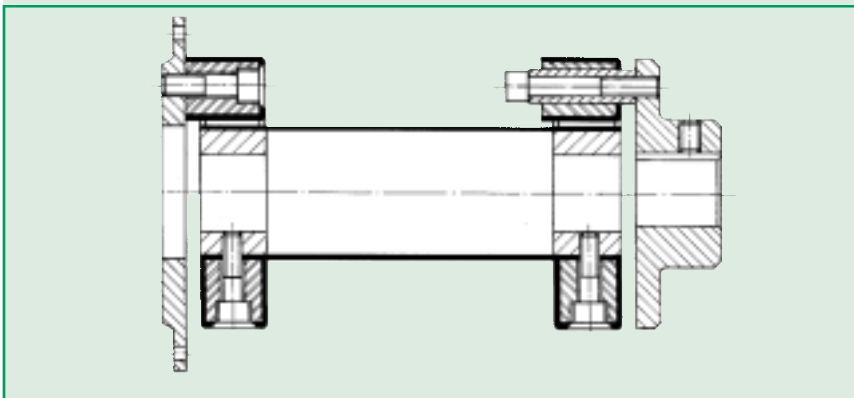

The CENTAFLEX universal joint shafts are proven, extremely simple, versatile and torsionally highly elastic.

They dampen noise, torsional oscillation and shock.

They compensate for considerable axial, radial and angular misalignment.

The lengths are not standardised, but made individually in accordance with customers' requirements; but they are, nonetheless very moderately priced. The connecting parts (hubs) can also be adapted to suit requirements. CENTAFLEX universal joint shafts require no maintenance whatsoever; the centre part can be removed radially (transversely) without displacing the coupled machines.

## Design G

This is the simplest design type; the centre part is centered only by the CENTAFLEX elements. Suitable for short and medium lengths and for speeds up to approx. 1500 rpm.

Please also see the diagram on page 11 for additional information.

## Design GZ

Here, the centre assembly is accurately located on the centering plate and maintenance free bearings. This design is suitable for long lengths and/or high speeds. The centre assembly can be withdrawn without disturbing the driving or driven hubs. In cases of doubt, the decision whether to choose design G or GZ should be left to us, since a clear demarcation is difficult.

The sectional drawing on the left shows one of the many special designs, with an adaptor plate for a diesel engine and with extensive axial movement permitted by means of long socket bolts.

## Selection of CENTAFLEX Universal Joint Shafts:

Torque capacity is in accordance with the table on page 6.

Due to the use of two CENTAFLEX elements, the values of axial elasticity and for the angle of twist are doubled, the values for torsional stiffness and the axial spring values are halved.

Permissible angular misalignment is shown in diagram A 1.7 and the following formula:

Design G:

$$a = \tan \alpha (L - 2H)$$

a = parallel offset (mm)

Design GZ:

$$a = \tan \alpha [L - 2(H + C)]$$

L; H and C as in dimension table.

The maximum permissible length



for the centre part is dependant on the speed and can be found in the diagram on the right.

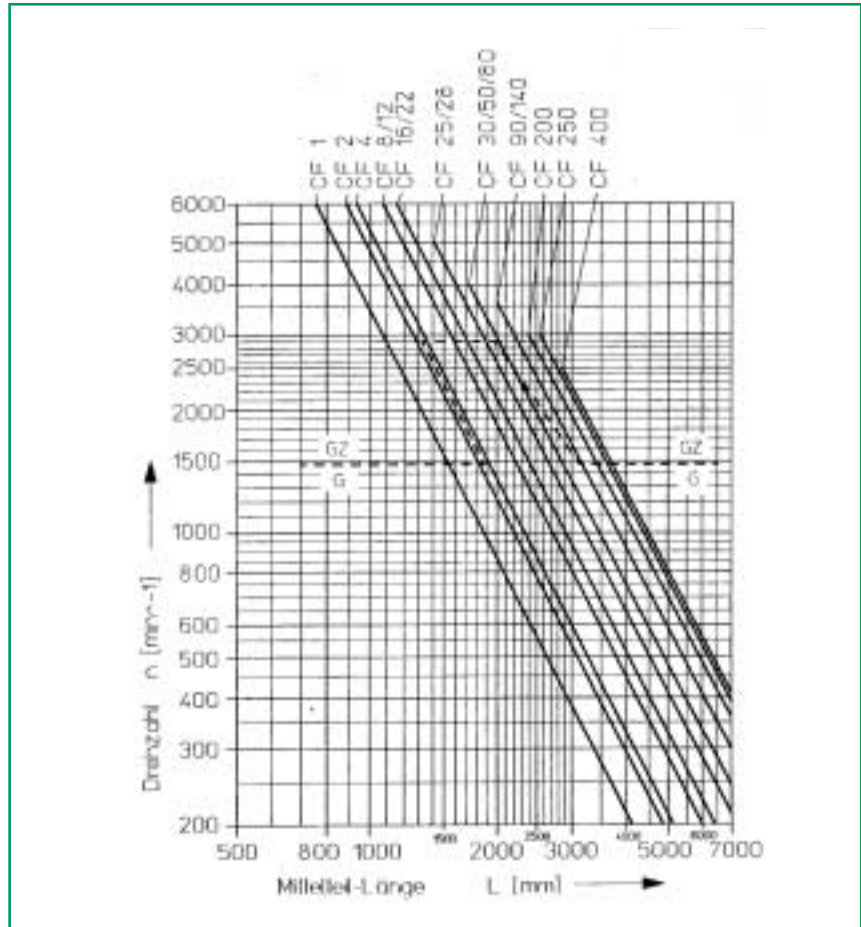

The dotted line gives an approximate indication as to whether type G or GZ should be used on short shafts, but only in respect of speed, not of length. We recommend that all shafts regardless of length are of the GZ type if they run at speeds above those indicated by the dotted line.

Examples of typical applications: Screw Jacks, compressors, engine test benches (Size 16 GZ; n = 7200 rpm). Other applications: Boat drives, diesel drives for centrifugal pumps, air conditioning, construction machinery, general mechanical engineering.

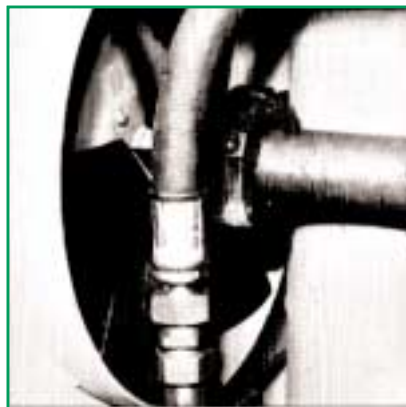

# CENTAFLEX-couplings for diesel engines

This is the central point of application for CENTAFLEX. We supply suitable CENTAFLEX couplings for practically any diesel or petrol engine, to suit the flywheel side as well as for the power take-off at the front end of the crankshaft, e.g. Caterpillar, Detroit, Deutz, Dorman, Ford, Gardner, Hatz, Leyland, Lister, MAN, Perkins, Petter, Rolls Royce, VW and many others.

The number of the existing assembly drawings is so great that it is not possible to include them in a brochure.

The type most extensively used for diesel engine flywheels is SAE standard J620. The dimensional sheet shows appropriate couplings for the plug-in (blind fitting) design (e.g. for generator drives).

For Deutz and Perkins engines, flywheels with tapped holes are available for CENTAFLEX couplings. This enables couplings to be fitted direct - without and adaptor plate- with types 1 and 1-S, and results in particularly compact and economically priced couplings.

Please ask for our detailed offer for your specific requirements.

- 1 Deutz F3-6L912 available for engines 208, 210, 511, 912, 913 and 413
- 2 Perkins 3, 4, 6 and 8 cylinders Perkins part-no. 31221322
- 3 Intermediate couplings for universal joint shafts.

## Type 3-S-SAE

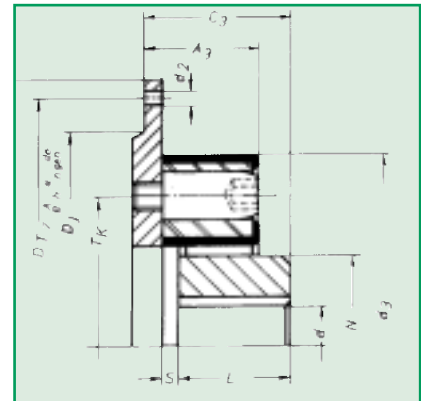

Size	d <sub>1</sub>		d <sub>3</sub>	A <sub>3</sub>	C <sub>3</sub>	L <sub>1</sub>	N <sub>1</sub>	S	T <sub>K</sub> /division	appropriate SAE-flange
	min.	max.								
8	12	38	120	38	52	42	60	4	100/3x120°	6½" 7½"
16	15	48	150	48	62	50	70	6	125/3x120°	6½" 7½" 8"
22	15	55	170	52	67	55	85	6	140/3x120°	8"
25	15	55	170	56	71	55	85	6	140/3x120°	10"
30	20	65	200	68	84	66	100	8	165/3x120°	10" 11½"
50	20	65	200	68	84	66	100	8	165/4x 90°	10" 11½"
90	30	85	260	80	98	80	125	8	215/3x120°	(10") 11½" 14"
140	30	85	260	80	98	80	125	8	215/4x 90°	(10") 11½" 14"
200	35	105	300	90	112	94	145	8	250/4x 90°	11½" 14" 16"
250	40	115	340	95	118	100	160	8	280/4x 90°	11½" 14" 16"
400	40	120	370	115	150	125	170	10	300/4x 90°	14" 16"

nominal SAE size	D <sub>A</sub> f7	D <sub>T</sub>	D <sub>J</sub>	d <sub>2</sub>	Z	weight kg	Mass moment of inertia J kgcm <sup>2</sup>
6½"	215,9	200,02	180	9	6	2,60	147
7½"	241,3	222,25	200	9	8	3,25	228
8"	263,52	244,47	220	11	6	3,90	328
10"	314,32	295,27	270	11	8	7,20	966
11½"	352,42	333,37	310	11	8	9,60	1584
14"	466,72	438,15	405	13	8	19,40	5421
16"	517,5	489	450	13	8	24,60	8272

Example of coupling reference CF-A-30-3-S-SAE10 \* Z = number of holes

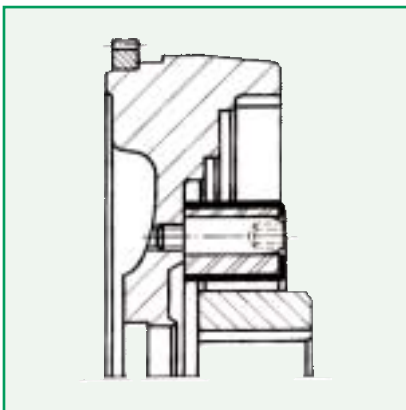

1

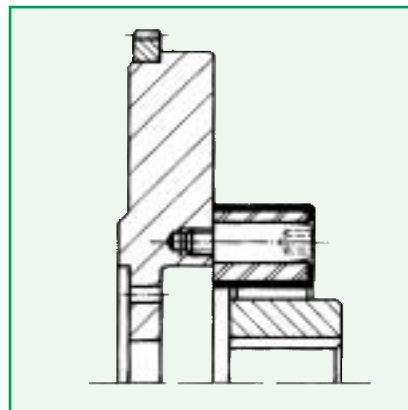

2

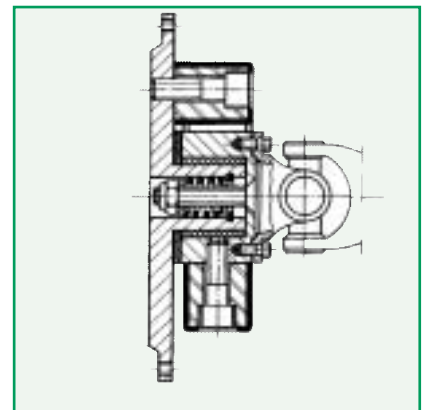

3

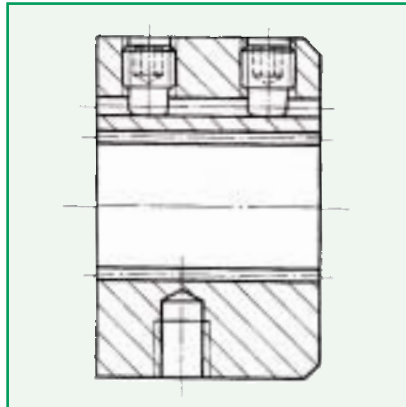
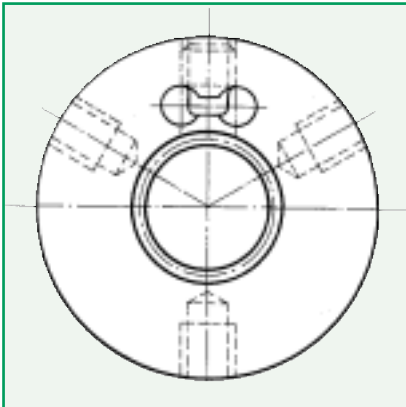

Path of clamping force

## CENTALOC Clamping Hub

It is well known that all splined steel connections, which are not free from play tend to wear due to “hammering” and fretting corrosion.

The shaft of hydrostatic pumps for mobile equipment nearly always have spline or involute profiles. The unavoidable play, due to the manufacturing tolerances on the flanks of these profiles between shaft and hub, permits minor relative movements in operation leading to wear. Even hubs and shafts made from high quality and hardened steels cannot solve this problem in its essence, but can at best only reduce the wear. The problem can be solved effectively only when the connection between shaft and hubs is made **free from play**.

With this objective in mind, we developed the CENTALOC clamping hub. This new type of clamp hub has a slot arranged tangentially to the bore. On the inner part of this slot, strong forces are applied through one or more set screws. The hub is radially pressed inwards in this area, i.e. pressed firmly against the shaft profile. The opposing reaction forces of the clamping screw are diverted within the hub causing it to be pressed firmly against the shaft. The hub thus becomes firmly locked against the shaft around its diameter i.e. **absolutely free from play**. It is at the same time also locked axially. The incidental minor deformations of the hub occur within the elastic limit and there is no permanent deformation. After slackening the clamping screws, the hub can easily be dismantled or re-fitted. This procedure can be repeated as often as may be required.

Use of the CENTALOC clamping hub does not present any difficulty at the assembly stage with the blind fitting design type S, H or X. When assembling for example a motor and pump, the cylindrical coupling hub is simply mounted on the pump shaft and locked prior to motor and pump being assembled together. The coupling housing does not, therefore, require any access holes.

The CENTALOC clamp hub can be selected for all design types of CENTAFLEX. The clamping should preferably be arranged in the cylindrical inner hub; but it is also possible to manufacture flanged hubs with the clamping facility.

The connecting details and external dimensions of the CENTAFLEX coupling are not altered by the CENTALOC clamping facility.

The patented CENTALOC clamp hub has already been proved in thousands of hard applications. It is recommended by major manufacturers of hydraulic pumps. This is evidence of the fact that you can expect real solutions to your problems for CENTA power transmission engineers.

# Fitting instructions for CENTAFLEX-couplings with highly elastic rubber elements

## Important notes - observe strictly

The radial and axial screws connecting the rubber element to the hubs must all be tightened to the torque given in the table below, using a **torque wrench**.

Tightening with a torque wrench is particularly important with the larger sizes. Tightening "by feel" will not do, as experience has proved the tightening torques in such cases are far too low.

Tightening torques which are too low will inevitably lead to slackening of the screws in service and consequently to the destruction of the coupling.

Ensure that on tightening the screws, the aluminium bushes in the rubber part are not twisted at the same time, but sit straight.

In order to reduce friction between the screw head and the aluminium part, a small amount of **grease** should be applied under the head of the screw before fitting. If necessary, use a suitable tool for applying counter pressure on the element to **prevent twisting of the rubber part** during tightening of the screws. This is particularly important with the **radial screws**, otherwise the cylindrical faces between aluminium insert and hub will not engage on the full area, but only on two corners. This will inevitably lead to slackening of the screws and subsequent destruction of the coupling. If the coupling is supplied in a pre-assembled state, do not dismantle it, but fit it in this condition.

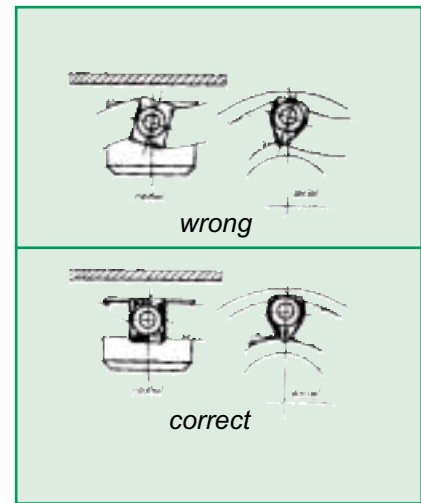

CENTAFLEX Size	1	2	4	8 / 12	16 / 22	25 / 28	30	50 / 80	90 / 140	200 / 250	400
Screw Size	M 6	M 8	M 8	M 10	M 12	M 14	M 16	M 16	M 20	M 20	M 20 / M24
Tightening torque Nm	10	25	25	50	85	140	220	220	500	500	610 / 1050
mKp	1,0	2,5	2,5	5	8,5	14	22	22	50	50	61 / 105

## Sequence of Assembly

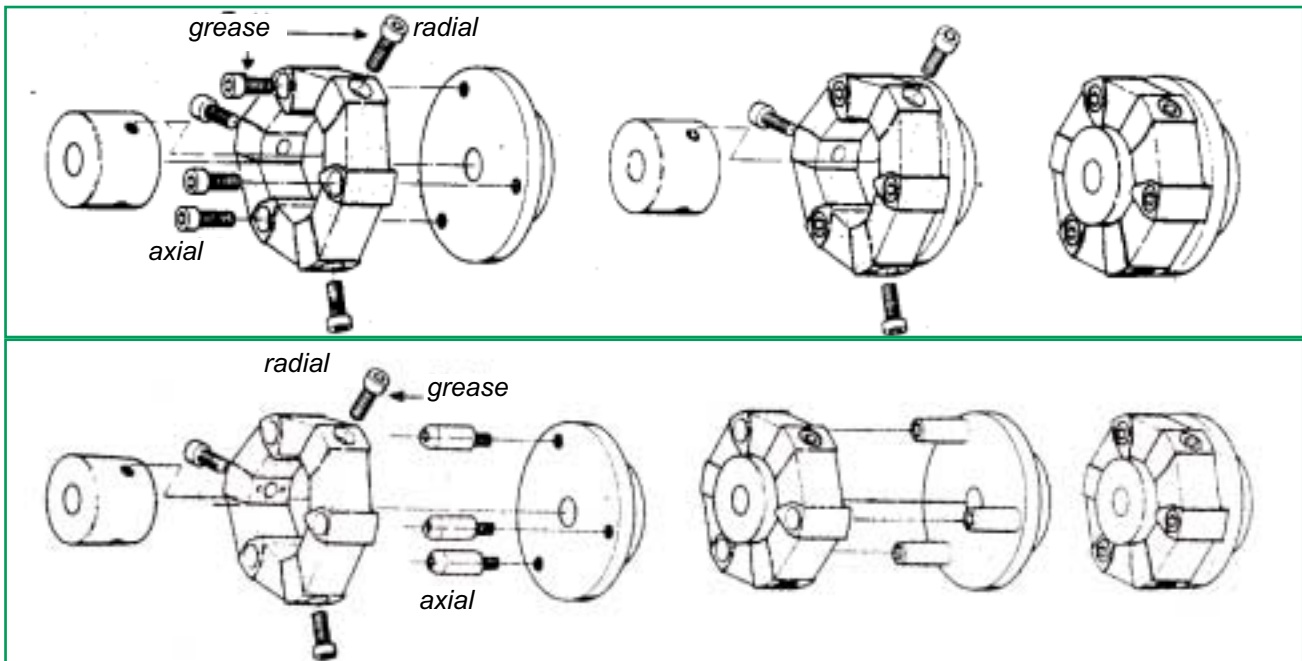

### Standard Design

Fit the hubs onto the shafts or the adaptor plate onto the flywheel.

Fit the rubber element to the flanged hub or flywheel, by means of **axial screws**. **This must be carried out before engaging the radial screws in the cylindrical hub.**

Push the shaft-mounted cylindrical hub inside the rubber element and then fasten the rubber element on it with radial screws. During this process, the rubber element is compressed radially and is pre-loaded for increased capacity.

### Design S (plug-in or blind fitting type)

Fit the hubs onto the shafts or the adaptor plate onto the flywheel.

Fit the axial socket bolts on the flange hub or adaptor plate on the flywheel.

Position the element with the side having the rubber free face of the axial aluminium inserts towards the flange hub and, using the radial screws, mount it on the cylindrical hub. During this process, the rubber element is pulled together radially and receives its pre-load. Then, push the cou-

pled elements together and in doing so, carefully slide the coupling with light axial pressure onto the socket bolts. The rubber element is subjected to a little more radial compression by the socket bolts, and the pre-load is thus increased. The axial bores in the rubber element should be smeared lightly with grease beforehand to allow the socket bolts to slide easily in the inserts.

Use only the "Inbus Plus" screws provided which are marked on the threads with a micro-encapsulated adhesive which locks the screw in the thread and secures them reliably against slackening. For adequate effect, the hardening period for this adhesive after bolting up is approximately 4-5 hours at room temperature (20°C). The coupling should not be operated before this period has elapsed.

The adhesive will be fully hardened after 24 hours. Higher temperatures will speed up the hardening process, at 70°C (using a hot air blower), for instance, the hardening will take only 15 minutes. Inbus Plus is temperature proof between -80° and +90°C and the screws can be reused up to 3 times max. Any adhesive stripped off during bolting up will settle between the hub and the aluminium part, but this will have a beneficial effect in that it enhances the friction grip between these parts.

**Note:** Anaerobic adhesives (such as Loctite, Omnifit etc.) will loosen the adhesion of the rubber and the insert and will consequently destroy the coupling.

Such adhesives should therefore be avoided if possible. Where the use of this adhesive is unavoidable apply it very sparingly so that no surplus adhesive will moisten the rubber.

We cannot accept any complaints concerning rubber parts which have become defective through the action of adhesives not supplied or recommended by us.

The coupling is completely maintenance-free and does not require any lubrication. Splashing with oil and similar substances should be avoided, since natural rubber is not oil-resistant.

However occasional minor contact with oil or grease is not harmful as this oil will be thrown off during rotation of the coupling.

### CENTALOC clamping hub

If the hubs are equipped with CENTALOC clamping (see page 13), the clamping screws must be tightened at least to the following tightening torques:

clamp screw	Tightening torque (Nm)
M 10	30
M 12	50
M 14	70
M 16	120
M 20	200

After assembly, the coupling should be carefully aligned if the coupled elements are not already in good alignment by virtue of being spigot located. In the interest of a long service life of the coupling, the higher the speed, the more meticulous should the alignment be. In design type 2, the alignment can very easily be checked with a straight edge. The outer diameter of the flange hub must be flush with the outer diameter of the rubber element in those areas where the radial screws sit: i.e. in different radial positions.

In design types 1 and 3 the distance "Z" must be measured at all axially bolted points of the rubber element (2, 3 or 4 points depending on the size) and must be set as accurately as possible to the value "Z" quoted in the table below.

For spigot located components there is no need to align the coupling.

### Position of cylindrical hubs:

The long end of the cylindrical hub, usually identifiably by a chamfer, is normally as shown in the drawing below. However, in some special applications, the hub must be reversed. When in doubt, install as shown in the relevant installation drawing.

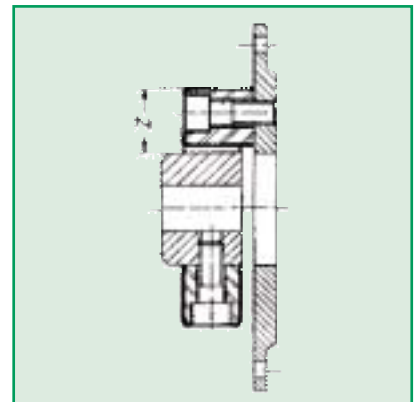
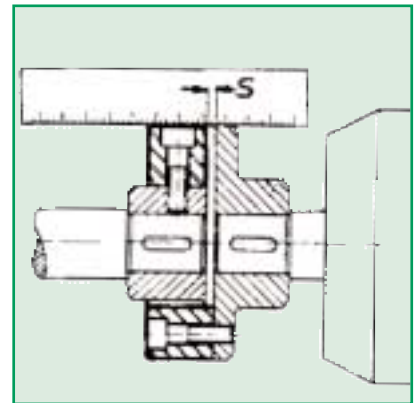

**Installation table: Screw fastener details, dimension "S" between the hubs and dimension "Z".**

CENTAFLEX Size	1	2	4	8 / 12	16 / 22	25 / 28	30	50 / 80	90	140	200	250	400
Standard Design	M6x10 M6x25	M8x20	M8x25	M10x30	M12x35	M14x40	M16x50	M16x50	M20x65	M20x65	M20x80	M20x80	M24x100 M20x100
Type "S" Special bolt screws	M6 M6x10	M8 M8x10	M8 M8x25	M10 M10x30	M12 M12x35	M14 M14x40	M16 M16x50	M16 M16x50	M20 M20x65	M20 M20x65	M20 M20x65	M20 M20x80	M24 M20x100
Universal joint shaft	M6x10												M24x100
G	M6x25	M8x20	M8x25	M10x30	M12x35	M14x40	M16x50	M16x50	M20x65	M20x65	M20x65	M20x80	M20x100
u/j shaft radial	M6x10	M8x20	M8x25	M10x30	M12x35	M14x40	M16x50	M16x50	M20x65	M20x65	M20x65	M20x80	M20x100
GZ axial	M6x30	M8x25	M8x30	M10x35	M12x40	M14x45	M16x55	M16x55	M20x70	M20x70	M20x80	M20x90	M24x100
Dimension "S"													
mm	2	4	4	4	6	6	8	8/4	8	8	8	8	10
Dimension "Z"													
mm	13	22,5	37,5	30/31	40	42,5	50	50/52,5	67,5	67,5	77,5	90	100